

On Choosing and Using Control Volumes: Six Ways of Applying the Integral Mass Conservation Theorem to a Simple Problem

Ain A. Sonin, MIT

2001, 6 pages

Reference: Ain A. Sonin, *Fundamental Laws of Motion for Particles, Material Volumes, and Control Volumes*, 2001

We shall use a very simple example to illustrate the variety of ways in which a control volume theorem can be applied to a particular application, depending on the choice of control volume and which of the two alternative forms of the control volume theorem is used. The exercise provides a few basic insights into the thought processes that are used in control volume analysis.

Figure 1 depicts something like a cylindrical syringe, or a grease gun, in which a solid piston of radius R_1 is pushed at a speed $U(t)$ into a fluid-filled cylinder with the same internal radius, forcing the fluid out through a tube with internal radius R_2 and length L . The piston, cylinder, and tube are inflexible and made of material with density ρ_s ; the fluid has density ρ and can be considered incompressible.

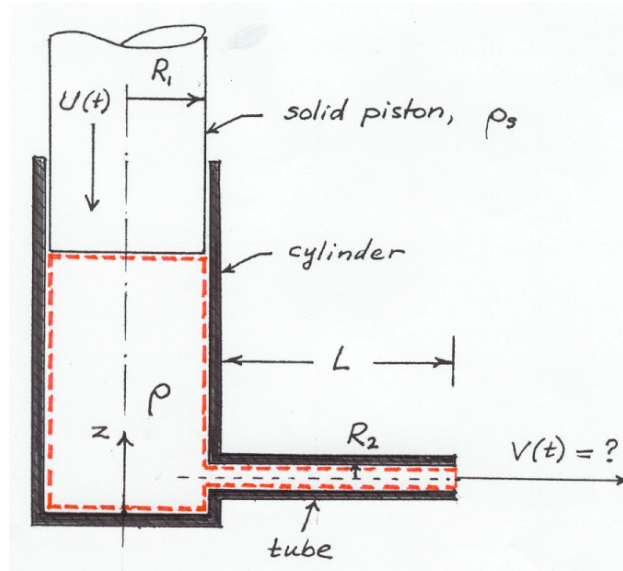

Fig. 1: The system and the control volume (broken red line) for Methods 1 and 2. This control volume is fixed in the inertial reference frame of the cylinder.

Given the aforementioned quantities, what is the average flow speed $V(t)$ of the fluid at the exit plane? The governing principle is clearly mass conservation, which can be written for a control volume in two alternative forms,

$$\text{Form A} \quad \frac{d}{dt} \int_{CV(t)} \rho dV + \int_{CS(t)} \rho v_{rn} dA = 0 \quad (1)$$

$$\text{Form B} \quad \int_{CV(t)} \frac{\partial \rho}{\partial t} dV + \int_{CS(t)} \rho v_n dA = 0 \quad (2)$$

where $v_n = \vec{v} \cdot \vec{n} = v \cos \theta$ is the outward normal velocity component of the fluid at the control surface, and $v_{rn} = (\vec{v} - \vec{v}_c) \cdot \vec{n}$ is the outward normal component of the fluid velocity *relative to the control surface* at that point. The answer is simple:

$$V(t) = \frac{R_1^2 U(t)}{R_2^2}. \quad (3)$$

Let us look at some of the different ways this result can be obtained.

In all the examples that follow, the *reference frame is fixed in the solid cylinder*.

Method 1

Control volume: As shown in Fig. 1, with all points of the control surface held fixed in the chosen reference frame. Note that the top of this CS is placed *just below* the piston face, that is, we choose to look at the situation at an instant *before* the piston's face reaches the fixed elevation of the top of our control surface. All parts of the CS reside *in the fluid*, where the density is ρ .

Equation: We shall apply Form A of mass conservation,

$$\frac{d}{dt} \int_{CV(t)} \rho dV + \int_{CS(t)} \rho v_{rn} dA = 0 \quad (1)$$

Analysis: The first term in (1) is zero because the fluid density is invariant and our control volume has a fixed volume, so that the mass contained within it is invariant. (We are considering a time just *before* the piston's face penetrates the top of the CS!) In the

second term, $v_n = -U(t)$ at the top of the CS where the piston face pushes the fluid down into the CV through a stationary CS with area πR_1^2 . At the exit plane the area is πR_2^2 and the velocity is $v_n = V(t)$ on the average. Elsewhere on the CS, $v_n = 0$. Equation (1) thus gives

$$\rho V \pi R_2^2 + \rho(-U) \pi R_1^2 = 0, \quad (4)$$

which is the same as (3).

Method 2

Control volume: Same as in Method 1.

Equation: Form B of the mass conservation equation,

$$\int_{CV(t)} \frac{\partial \rho}{\partial t} dV + \int_{CS(t)} \rho v_n dA = 0. \quad (2)$$

Analysis: In this case the volume integral is zero because the density is invariant with time. The integral over the CS is exactly the same as in Method 1, and we end up with (3) again.

Method 3

Control volume: As shown in Fig. 2, i.e. similar to the one in Fig. 1 except that *the top surface moves downward at the piston speed U* , keeping just a hair ahead of the piston face, that is, the CV height $h(t)$ is such that

$$\frac{dh}{dt} = -U(t). \quad (5)$$

Equation: Form A of the mass conservation theorem,

$$\frac{d}{dt} \int_{CV(t)} \rho dV + \int_{CS(t)} \rho v_n dA = 0 \quad (1)$$

Analysis: In this case the first term in (1) is non-zero because the CV's volume changes as the piston moves down and h decreases. The outflow term in the surface integral is the same as before, but there is no inflow into the CV from the top because the fluid moves down at the same speed as the piston. Equation (1) yields

$$\frac{d}{dt}[\rho\pi R_1^2 h(t) + \rho\pi R_2^2 L] + \rho V(t)\pi R_2^2 = 0 \quad (6)$$

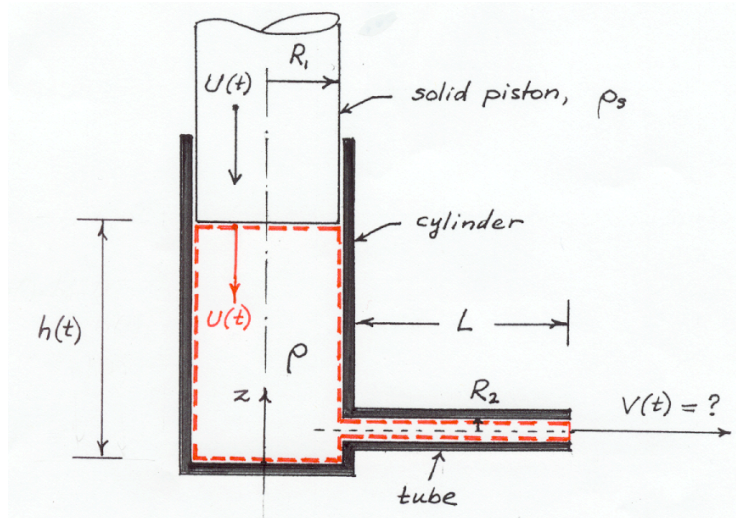

Fig. 2: Control volume for Methods 3 and 4 (broken red line). The top moves down under the piston.

where the quantity in square brackets in (6) is the volume integral of the density within the CV. We evaluate the time derivative in (6) using (5), and again obtain (3).

Method 4

Control volume: Same as in Method 3. See Fig. 2.

Equation: Form B of the mass conservation theorem,

$$\int_{CV(t)} \frac{\partial \rho}{\partial t} dV + \int_{CS(t)} \rho v_n dA = 0. \quad (2)$$

Analysis: The first term is zero because the density does not vary with time. The surface integral involves the normal fluid velocity, not the normal relative velocity. (The control surface velocity appears nowhere in (2)!) Equation (2) reads

$$0 + [-\rho U(t)\pi R_1^2 + \rho V(t)\pi R_2^2] = 0 \quad (7)$$

where the term in square brackets is the surface integral.

Method 5

Control volume: This time we deliberately pick a less thoughtful control volume—one with a *fixed* upper bounding surface that cuts through the piston at a *fixed* elevation h_o (Fig. 3).

Equation: Form A of the mass conservation theorem,

$$\frac{d}{dt} \int_{CV(t)} \rho dV + \int_{CS(t)} \rho v_m dA = 0 \quad (1)$$

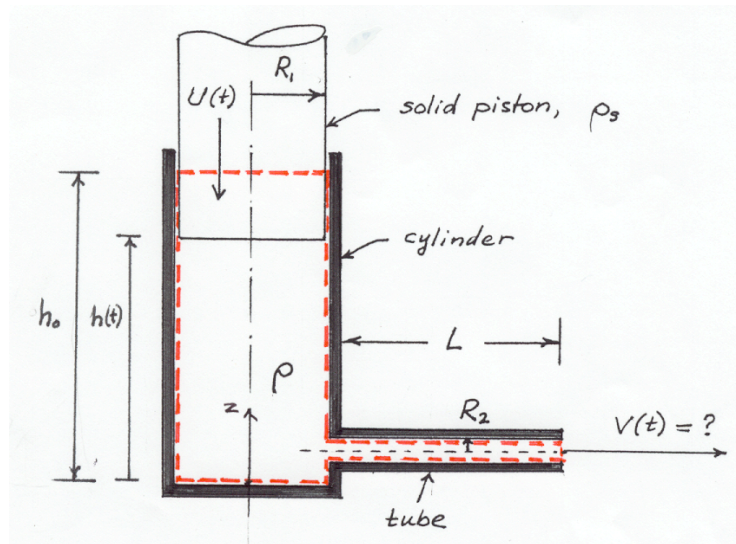

Fig. 3: Control volume for Methods 5 and 6 (broken red line). The control volume is fixed.

Analysis:

$$\frac{d}{dt} [\rho\pi R_1^2 h + \rho_s\pi R_1^2 (h_o - h) + \rho\pi R_2^2 L] + [-\rho_s U\pi R_1^2 + \rho V\pi R_2^2] = 0 \quad (8)$$

Here $h(t)$ is the elevation of the piston face, the first term in square brackets is the volume integral of density, and the second term in square brackets is the surface integral of mass flux.. Evaluating the time derivative using (5), we find that (8) reduces to (3).

Method 6

Control volume: Same as in Method 5.

Equation used: Form B of the mass conservation theorem,

$$\int_{CV(t)} \frac{\partial \rho}{\partial t} dV + \int_{CS(t)} \rho v_n dA = 0. \quad (2)$$

Analysis: When we now try to apply Form B, we encounter a difficulty: the partial time derivative of density is zero everywhere except at the piston face, where it is singular. At any height z inside the cylinder, the density is equal to the fluid density ρ before the piston arrives, jumps discontinuously to the solid density ρ_s at the instant the piston arrives, and stays at that value thereafter. If for example the piston velocity is constant, this can be expressed as

$$\begin{aligned} \rho &= \rho & z < h_o - Ut \\ \frac{\partial \rho}{\partial t} &\rightarrow \infty & z = h_o - Ut \\ \rho &= \rho_s & z > h_o - Ut \end{aligned} \quad (9)$$

The singularity makes it difficult to evaluate the volume integral of the time derivative of the density. It is possible to integrate this particular singularity by representing the partial time derivative of the density with a suitable Dirac delta function. We will not do that here, for it requires an introduction to generalized functions (see, however, Problem 3.7 for an analogous problem with a solution provided). A better way to proceed with this CV choice (if one is fixated on it) is to use Form A of the mass conservation theorem, that is, Method 5.